

High Voltage DC Contactor

CBVC8 SERIES DC CONTACTOR



1 Product Features

Model	CBVC8P-400E
Outline Dimensions	Detail See 5.1
Weight	Approx.400±15g
Seal Type	Ceramic seal
Contact Type	1 Form A
Contact Material	Copper Alloy
Auxiliary Contact Type	1 Form A

2 Model Information

CBVC8 P - 400 E / 1500 - 24D - H A C 5 (XXX)

① ② ③ ④ ⑤ ⑥ ⑦ ⑧ ⑨ ⑩ ④

①	Product Series	CBVC8
②	Application	P : PV and energy storage
③	Lode Current	400 : 400A
④	Model Type	E:E Type
⑤	Lode Voltage	1000 : 1000 Vd.c. 1500 : 1500 Vd.c.
⑥	Coil Voltage	12D:12 Vd.c.Double coil 24D:24 Vd.c.Double coil
⑦	Contact Type	H: 1 Form A
⑧	Auxiliary Contact Type	A : 1 Form A
⑨	Coil Lead Out Wire Type	C: Connector
⑩	Load Outlet End	5: Female/internal thread
④	Special Code	customer demand (Only for special requirements)

3 Coil Parameter

Rated Voltage (Vd.c.)	12	24
Coil Type	Dual-coil	Dual-coil
Max. Operating Voltage (Vd.c.)	18	36
Operate Voltage (Vd.c.)(at 23 °C)	≤9.6	≤19.2
Release Voltage (Vd.c.)(at 23 °C)	≥1.2	≥2.4
Coil Resistance (Ω) (at 23 °C)	Start : 4x(1±7%) Holding : 24x(1±7%)	Start : 16x(1±7%) Holding : 96x(1±7%)
Coil Rated Power (W)	Start power : Approx 36w Holding power : Approx 6w	Start power : Approx 36w Holding Power : Approx 6w

4 Contact Parameter

Main contact parameter	Rated load of contacts	400 A (≥200mm ² wire)
	Operating Voltage Range	12~1500V
	Max. Breaking Current	2000A 1000Vd.c. (1 op)
	Min. Applicable Load	6 Vd.c. 1 A
	Contact Resistance	≤0.3 mΩ (at 400A 23°C)
	Current Endurance (85°C, 200mm ²)	400A /cont. 600A 30s 900A 10s 2000A 100ms
	Operate Time	≤30 ms
	Release Time	≤10 ms
	Bounce Time	≤5 ms
Aux contact parameter	Contact Resistance	≤120mΩ(at 1A 23°C)
	Rated load of Contacts	6 Vd.c. 0.1 A

Endurance	Electrical Endurance (23°C, on-off : 0.6s : 5.4s)	Turn on: 400A 20Vd.c. 1.5×10 ⁴ times ops Breaking: 20A 1500Vd.c. 1×10 ⁴ times ops Breaking: 250A 1500Vd.c. 150 times ops Breaking: 400A 1500Vd.c. 100 times ops Breaking: 2000A 1000Vd.c. 1 time op	
	Anti-short circuit	8000A 5ms With no fire or explosion	
	Mechanical Endurance	2×10 ⁵ times ops	
Safety Insulation	Insulation Resistance	When disconnected between main contacts	Initial : ≥1000MΩ(1500 Vd.c. 1min)
		Between main and auxiliary contacts	Initial : ≥1000MΩ(1500 Vd.c. 1min)
		Between main contacts and coils	Initial : ≥1000MΩ(1500 Vd.c. 1min)

	Dielectric Withstand Voltage (Leak Current: ≤ 1 mA)	When disconnected between main contacts	Initial : ≥ 4000 Va.c. (50/60 Hz 1 min)
		Between main and auxiliary contacts	Initial : ≥ 4000 Va.c. (50/60 Hz 1 min)
		Between main contacts and coils	Initial : ≥ 4000 Va.c. (50/60 Hz 1 min)
Mechanical Character	Vibration	49m/s ² , 10~55Hz, sine wave	
	Impact Stability	Off : : 98m/s ² , 11ms, half sine wave On : 98m/s ² , 11ms, half sine wave	
	Impact Strength	490m/s ² , 6ms, half sine wave	
Operating Condition	Temperature	-40 °C ~ 85 °C	
	Humidity	5 % ~ 85 % RH	
	Mounting Direction	Vertical	
	Note: The ambient environment of application shall not cause any dewing or icing inside the relay. Otherwise, the relay may fail to work.		
Storage Condition	Temperature	-40 °C ~ 85 °C	
	Humidity	5 % ~ 85 % RH	
	Storage Period	12 Months (with original package)	
	Storage Environment	Store in locations where the product is not exposed to corrosive gas.	
Keep product is not exposed to the direct ray of the sun.			

5 Product Structure

5.1 Outline Dimensions :

CBVC8P-400E/XXX-XX-HAC5

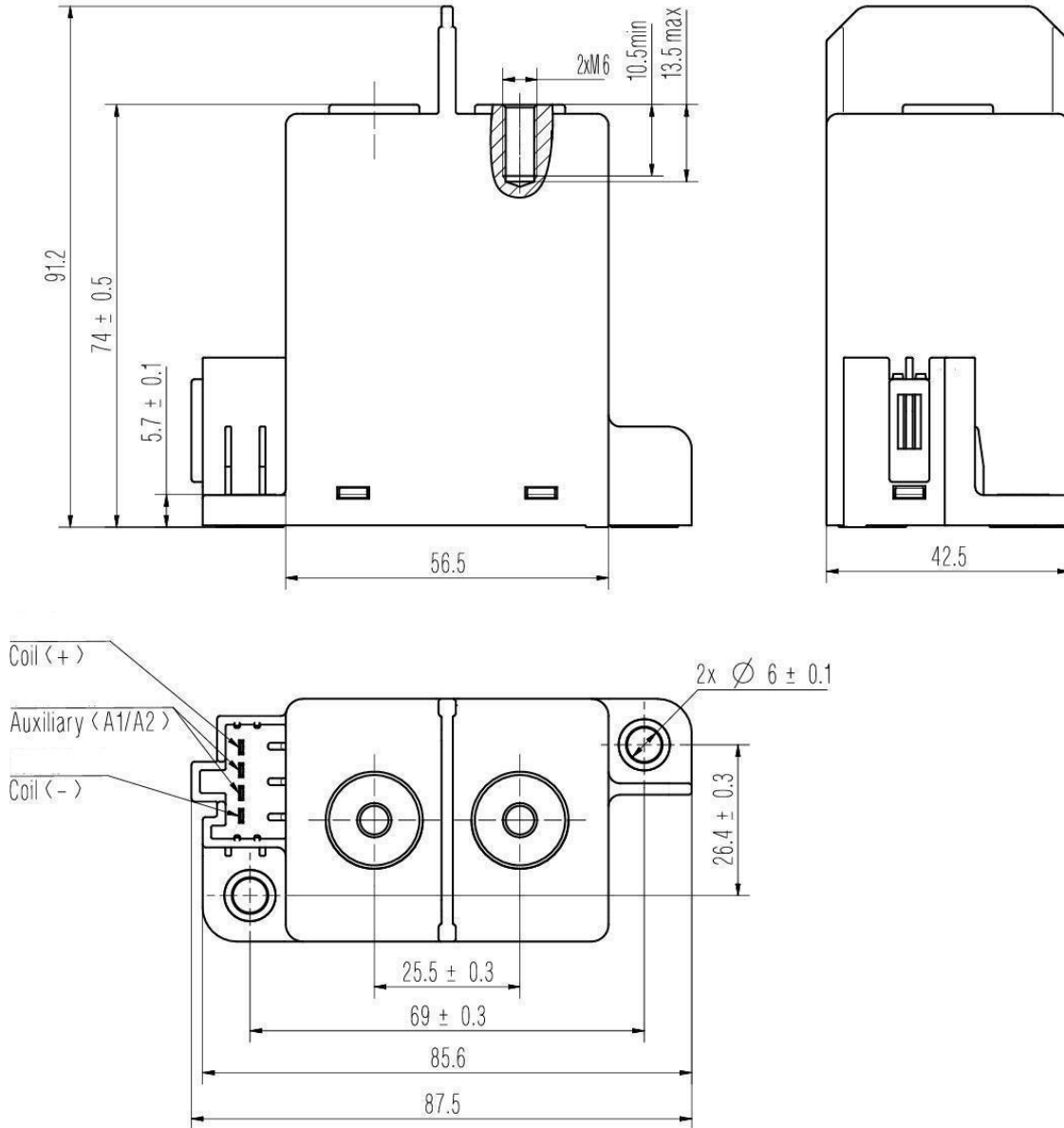

5.2 Wiring Diagram

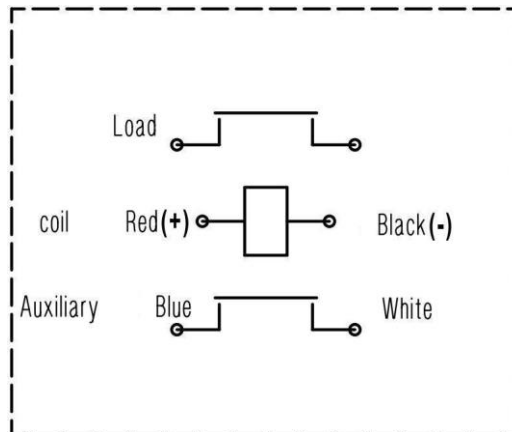

Load non-polarity; Auxiliary contacts have no polarity; coil has polarity

Notes : 1. The dimensions of the product without specified tolerances shall be executed according to the table below

Product dimensions without specified tolerances	
Prodcut Outline Dimensions	Tolerance
≤10	±0.3
> 10~50	±0.5
> 50	±0.8

2. The specific models of connectors that the product can adapt to are as follows :

Brand	Connector number
THB	0488701
Yazaki	7283-1044

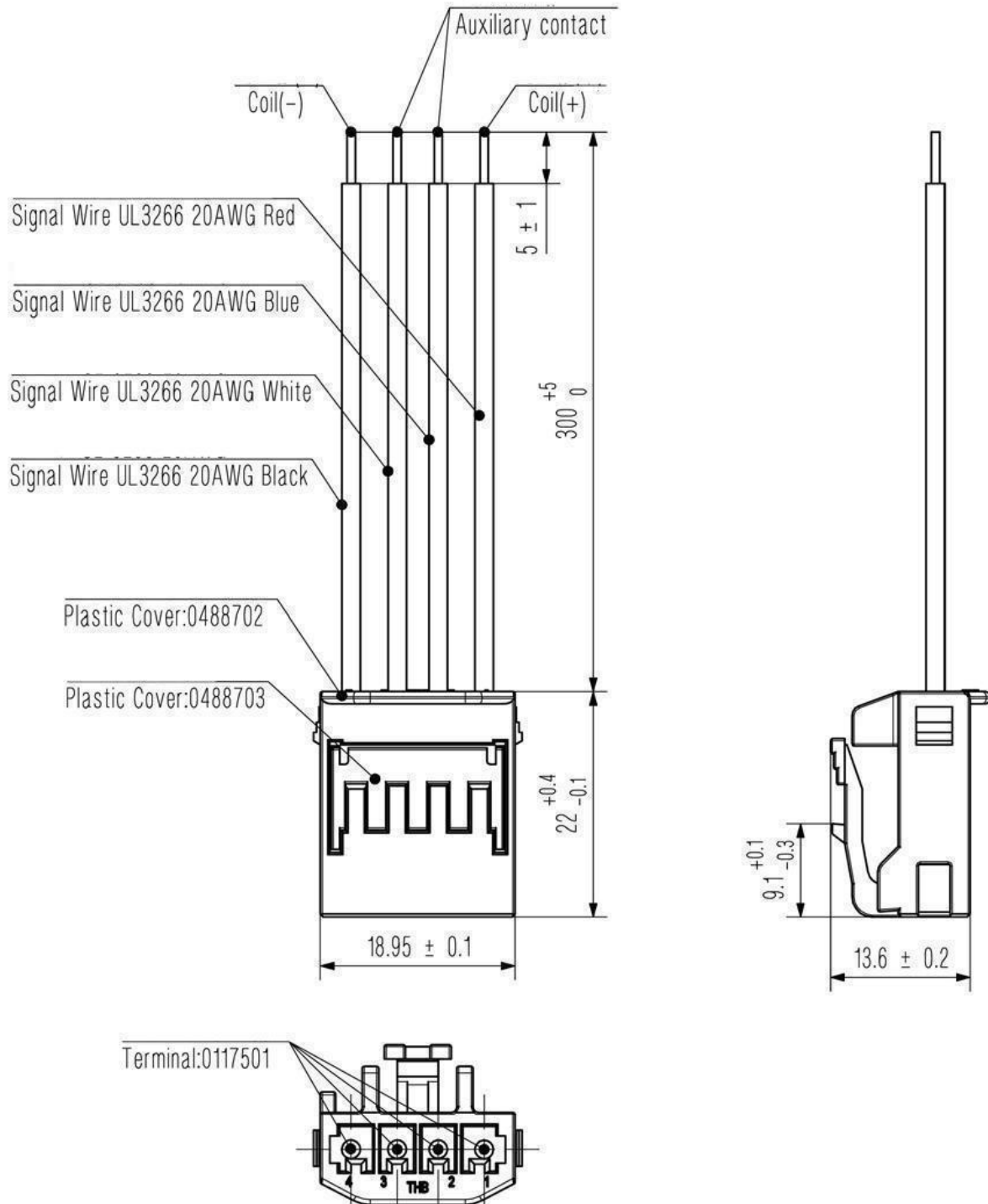

3. The product defaults to shipping connectors and harnesses, but does not include installation accessories such as screws, washers, and spring washers. Please notify separately if there is a need.

6 Others

6.1 Manufacturer

Component Basics

6.2 All the parameters listed in the datasheet are the initial values tested under standard testing condition.

6.3 Notice

- 6.3.1** CBV could not evaluate all the performance and all the parameters for every potential application. The customer can choose the right product according to the specific usage conditions and requirements. If there is any queries, please contact CBV for the technical service. However, customer will responsible for what they choose and it is the user's responsibility to determine which product should be used.
- 6.3.2** The load conditions promised by our company, unless otherwise specified, all refer to the rated load. If the product is used outside of the load conditions promised by us, our company will not be responsible for any failure caused by this.
- 6.3.3** The rated values of the contacts are all values for resistive loads. When using an inductive load (L load) with $L/R \geq 1$ ms, please take surge absorption measures in parallel with the inductive load. Without taking measures, it may lead to a decrease in electrical lifespan and poor disconnection.
- 6.3.4** The internal contacts of this relay are protected by gas, and there may be internal gas penetration due to changes in contact temperature (ambient temperature + temperature rise caused by power on). It is strictly prohibited to place the relay in an environment beyond the product temperature range (-40 °C to 85 °C) for a long time.
- 6.3.5** Please avoid installing near strong magnetic boundaries (transformers, magnets) and heating objects.
- 6.3.6** To prevent loosening, please use washers when installing the relay. Please use M5 screws for the installation of the relay, and control the locking torque of the screws between 3N · m and 4N · m.
- 6.3.7** When using M5 screws, ensure that the gasket thickness and strength are sufficient, otherwise it will deform and break the shell.

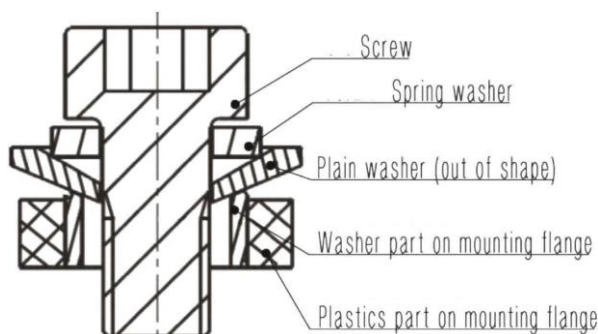

- 6.3.8** Please avoid sticking grease and other foreign objects on the lead out piece. Please use connecting wires with a size of 200mm² or above, otherwise it may cause abnormal heating at the lead out end.
- 6.3.9** Pay attention to the thickness and torque of the connecting copper bars. If the values recommended in the table are exceeded, it may cause thread slippage or loose installation. It is not recommended to install two copper bars on the same side to avoid high voltage short circuits or ignition.

Size of load outlet screw	Suggested copper bar thickness	Suggested hole dimension of copper bus bar	Torque
Female/internal thread M6	5 mm	Φ6.0mm~Φ6.5mm	6 N·m~8 N·m

- 6.3.10** In the event of a relay falling, please do not use it again as a principle.
- 6.3.11** Environmental Protection
CBV products are all RoHS compliant.
- 6.3.12** CBV reserves the right to make changes to the product. Customers should confirm the content of this specification before placing their first order, and may request our company to provide new specifications if necessary.

7 ABOUT US

Component Basics (“CBV”) datasheets are solely intended to assist designers (“Buyers”) who are developing systems that incorporate CBV products (also referred to herein as “components”). Buyer understands and agrees that Buyer remains responsible for using its independent analysis, valuation, and judgment in designing Buyer’s systems and products. CBV datasheets have been created using standard laboratory conditions and engineering practices. CBV has not conducted any testing other than that specifically described in the published documentation for a particular datasheet. CBV may make corrections, enhancements, improvements, and other changes to its datasheets or components without notice.

Buyers are authorized to use CBV datasheets with the CBV component(s) identified in each particular datasheet. HOWEVER, NO OTHER LICENSE, EXPRESS OR IMPLIED, BY ESTOPPEL OR OTHERWISE TO ANY OTHER CBV INTELLECTUAL PROPERTY RIGHT, AND NO LICENSE TO ANY THIRD PARTY TECHNOLOGY OR INTELLECTUAL PROPERTY RIGHT, IS GRANTED HEREIN. CBV DATASHEETS ARE PROVIDED “AS IS”. CBV MAKES NO WARRANTIES OR REPRESENTATIONS WITH REGARD TO THE DATASHEETS OR USE OF THE DATASHEETS, EXPRESS, IMPLIED, OR STATUTORY, INCLUDING ACCURACY OR COMPLETENESS. CBV DISCLAIMS ANY WARRANTY OF TITLE AND ANY IMPLIED WARRANTIES OF MERCHANTABILITY, FITNESS FOR A PARTICULAR PURPOSE, QUIET ENJOYMENT, QUIET POSSESSION, AND NON-INFRINGEMENT OF ANY THIRD PARTY INTELLECTUAL PROPERTY RIGHTS WITH REGARD TO CBV DATASHEETS OR USE THEREOF.

All products are sold subject to CBV’s terms and conditions of sale supplied at www.componentbasics.com. CBV ASSUMES NO LIABILITY FOR APPLICATIONS ASSISTANCE OR THE DESIGN OF BUYERS’ PRODUCTS. BUYER ACKNOWLEDGES AND AGREES THAT IT IS SOLELY RESPONSIBLE FOR COMPLIANCE WITH ALL LEGAL, REGULATORY, AND SAFETY-RELATED REQUIREMENTS CONCERNING ITS PRODUCTS, AND ANY USE OF CBV COMPONENTS IN ITS APPLICATIONS, NOTWITHSTANDING ANY APPLICATIONS-RELATED INFORMATION OR SUPPORT THAT MAY BE PROVIDED BY CBV.

Mailing Address: Component Basics, 1539, 35-Viking Lane, Toronto, M9B 0A2, ON, Canada.

Email: info@componentbasics.com