

# DC High-Voltage Fuses

## CBP-ESX SERIES FUSE



- **Semiconductor Protection Fuses – IEC60269-4 Compliant**

| Size | Rated Voltage | Operating Class | Rated Breaking Capacity        |          |
|------|---------------|-----------------|--------------------------------|----------|
| C    | 1500Vdc       | aR              | <700A@250kA<br>700A&750A@100kA | TC: <5ms |

- **Series Reference**

**CBP-ESX-C-H/E 100A-750A**

- **Key Features & Benefits**

- **Optimized for Energy Storage:** Specifically engineered for the demanding protection requirements of Battery Energy Storage Systems (BESS), PCS units, and other high-voltage DC applications.
- **Superior Electrical Performance:** Offers excellent current-limiting capabilities and a low  $I^2t$  value to rapidly and safely interrupt fault currents, protecting sensitive semiconductor devices.
- **Reliable & Secure Connection:** Features a robust bolt-on mounting design (US Style) ensuring safe, reliable, and low-resistance electrical connections.
- **Certified Quality:** Designed in conformance with IEC 60269-4 standards for semiconductor protection and manufactured in a process conforming to IATF 16949 automotive quality standards. All materials and packaging are RoHS compliant.

● Dimensions

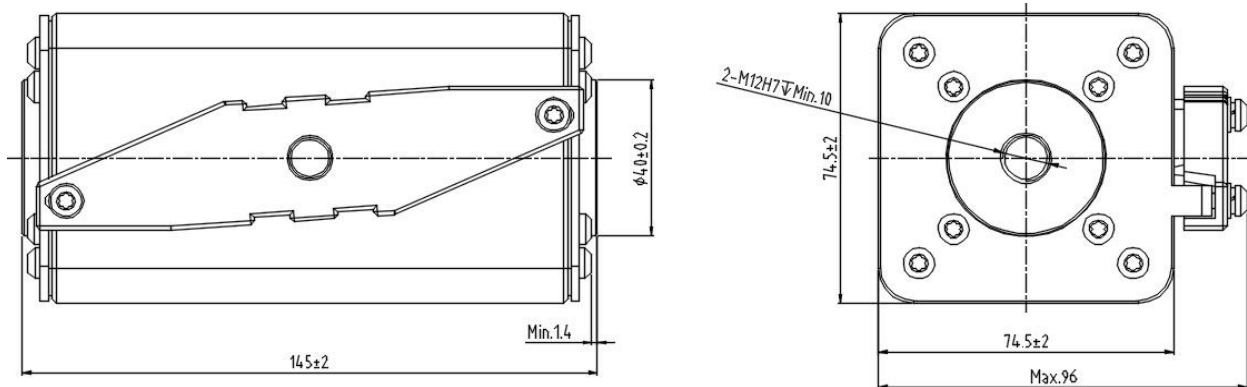

CBP-ESX-C-H

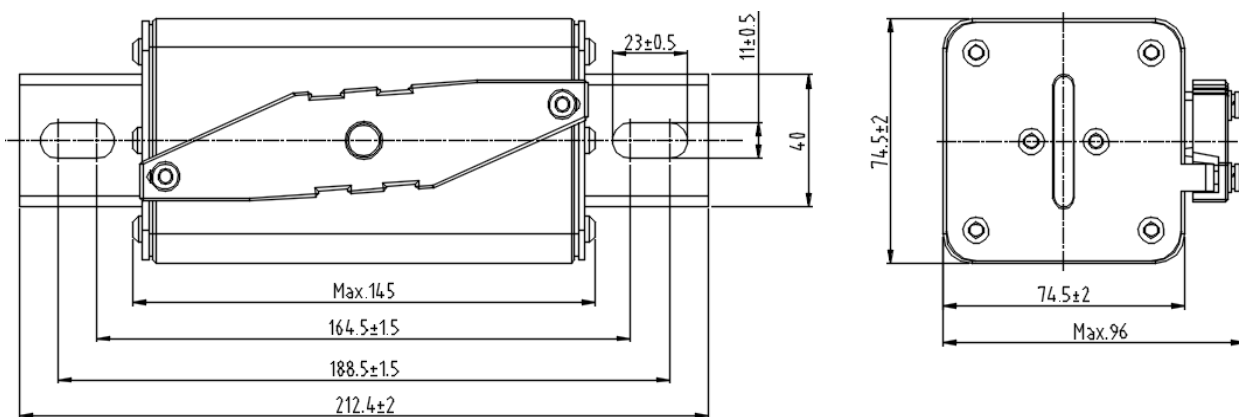

CBP-ESX-C-E

● Specification Matrix

| Rated Current (A) | Rated Voltage (V) | Part Number    |                | Power Loss (W) (typ.) | Pre-arcing I <sup>2</sup> t (A <sup>2</sup> s) | Total Clearing I <sup>2</sup> t @ 1500V (A <sup>2</sup> s) | Pack Q |
|-------------------|-------------------|----------------|----------------|-----------------------|--|--|--------|
| 100               | 1500Vdc           | CBP-ESX-C-100H | CBP-ESX-C-100E | 40                    | 1100   | 7000   | 1      |
| 125               | 1500Vdc           | CBP-ESX-C-125H | CBP-ESX-C-125E | 50                    | 2000   | 11000  | 1      |
| 160               | 1500Vdc           | CBP-ESX-C-160H | CBP-ESX-C-160E | 65                    | 3800   | 18000  | 1      |
| 200               | 1500Vdc           | CBP-ESX-C-200H | CBP-ESX-C-200E | 75                    | 5800   | 35000  | 1      |
| 250               | 1500Vdc           | CBP-ESX-C-250H | CBP-ESX-C-250E | 85                    | 13500  | 72000  | 1      |
| 315               | 1500Vdc           | CBP-ESX-C-315H | CBP-ESX-C-315E | 90                    | 23800  | 135000   | 1      |
| 350               | 1500Vdc           | CBP-ESX-C-350H | CBP-ESX-C-350E | 100                   | 33600  | 175000   | 1      |
| 400               | 1500Vdc           | CBP-ESX-C-400H | CBP-ESX-C-400E | 108                   | 58500  | 310000   | 1      |
| 450               | 1500Vdc           | CBP-ESX-C-450H | CBP-ESX-C-450E | 120                   | 75000  | 350800   | 1      |
| 500               | 1500Vdc           | CBP-ESX-C-500H | CBP-ESX-C-500E | 130                   | 95000  | 455000   | 1      |
| 550               | 1500Vdc           | CBP-ESX-C-550H | CBP-ESX-C-550E | 140                   | 108000   | 513000   | 1      |
| 600               | 1500Vdc           | CBP-ESX-C-600H | CBP-ESX-C-600E | 150                   | 158000   | 721000   | 1      |
| 630               | 1500Vdc           | CBP-ESX-C-630H | CBP-ESX-C-630E | 158                   | 168000   | 785000   | 1      |
| 700               | 1500Vdc           | CBP-ESX-C-700H | \              | 175                   | 253000   | 1188000  | 1      |
| 750               | 1500Vdc           | CBP-ESX-C-750H | \              | 190                   | 348000   | 1958000  | 1      |

● Time- Current Characteristics Curve

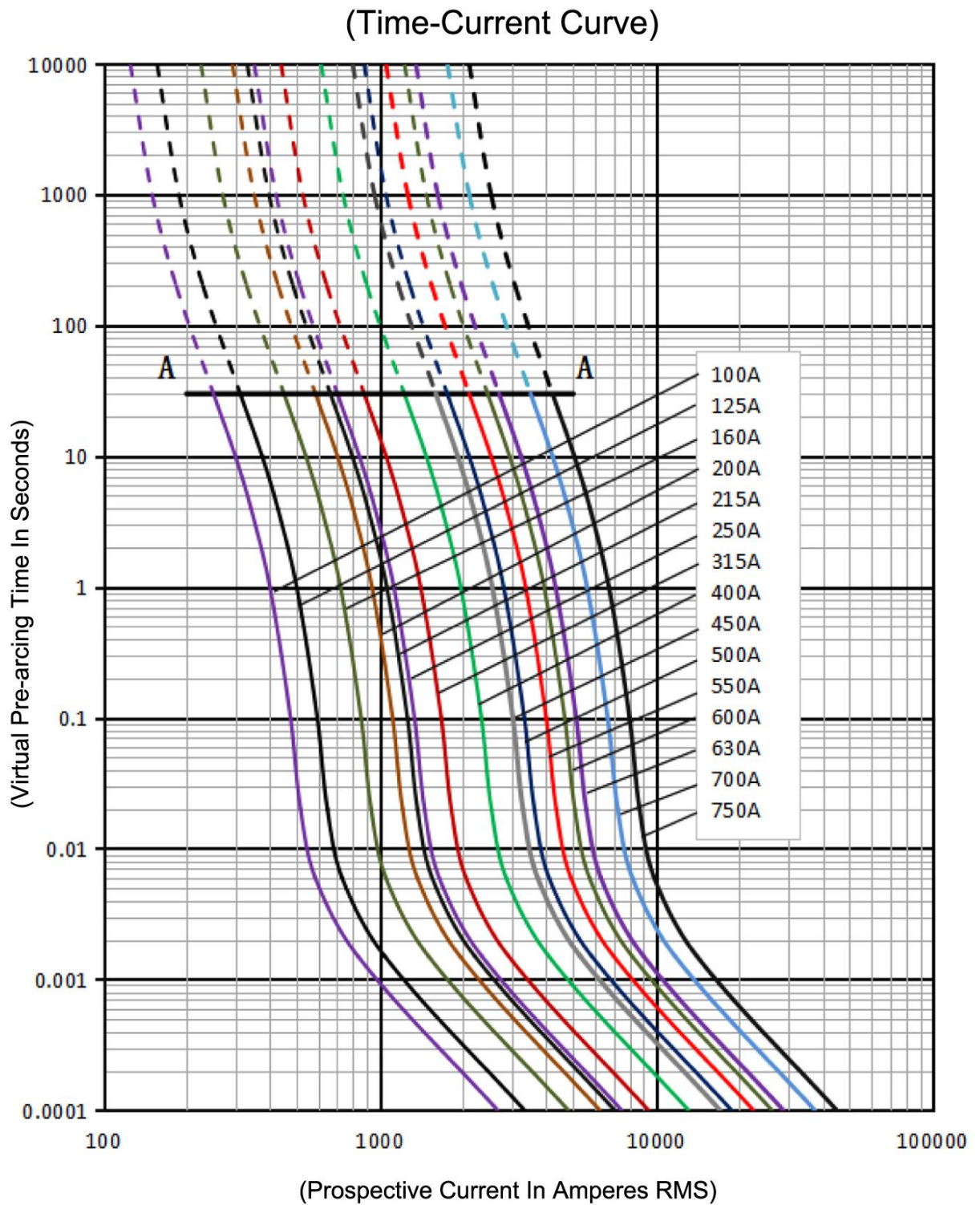

## ● Usage Conditions

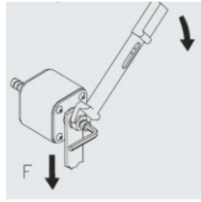
| No | Parameter                    | Specification   |
|----|------------------------------|---|
| 1  | <b>Operating Voltage</b>     | 1500V DC or less  |
| 2  | <b>Operating Environment</b> | -40°C~85°C  |
|    |                              | <b>Relative Humidity:</b> <50%(≥40°C)   |
|    |                              | <b>Relative Humidity:</b> <90%(≤20°C)   |
| 3  | <b>Storage Conditions</b>    | <b>Temperature :</b> -5°C~40°C<br><b>Relative Humidity:</b> <75%  |
| 4  | <b>Maximum Altitude</b>      | ≤ 2000 meters (Consult factory for operation above this altitude)   |
| 5  | <b>Mounting Torque</b>       | M12(8.8) studs:8Nm<br>M12(8.8) nuts:39Nm<br>M10:22Nm<br> |
| 6  | <b>Pollution Degree</b>      | III (Suitable for industrial environments)  |

## ● ABOUT US

Component Basics ("CBV") datasheets are solely intended to assist designers ("Buyers") who are developing systems that incorporate CBV products (also referred to herein as "components"). Buyer understands and agrees that Buyer remains responsible for using its independent analysis, valuation, and judgment in designing Buyer's systems and products. CBV datasheets have been created using standard laboratory conditions and engineering practices. CBV has not conducted any testing other than that specifically described in the published documentation for a particular datasheet. CBV may make corrections, enhancements, improvements, and other changes to its datasheets or components without notice.

Buyers are authorized to use CBV datasheets with the CBV component(s) identified in each particular datasheet. HOWEVER, NO OTHER LICENSE, EXPRESS OR IMPLIED, BY ESTOPPEL OR OTHERWISE TO ANY OTHER CBV INTELLECTUAL PROPERTY RIGHT, AND NO LICENSE TO ANY THIRD PARTY TECHNOLOGY OR INTELLECTUAL PROPERTY RIGHT, IS GRANTED HEREIN. CBV DATASHEETS ARE PROVIDED "AS IS". CBV MAKES NO WARRANTIES OR REPRESENTATIONS WITH REGARD TO THE DATASHEETS OR USE OF THE DATASHEETS, EXPRESS, IMPLIED, OR STATUTORY, INCLUDING ACCURACY OR COMPLETENESS. CBV DISCLAIMS ANY WARRANTY OF TITLE AND ANY IMPLIED WARRANTIES OF MERCHANTABILITY, FITNESS FOR A PARTICULAR PURPOSE, QUIET ENJOYMENT, QUIET POSSESSION, AND NON-INFRINGEMENT OF ANY THIRD PARTY INTELLECTUAL PROPERTY RIGHTS WITH REGARD TO CBV DATASHEETS OR USE THEREOF.

All products are sold subject to CBV's terms and conditions of sale supplied at [www.componentbasics.com](http://www.componentbasics.com). CBV ASSUMES NO LIABILITY FOR APPLICATIONS ASSISTANCE OR THE DESIGN OF BUYERS' PRODUCTS. BUYER ACKNOWLEDGES AND AGREES THAT IT IS SOLELY RESPONSIBLE FOR COMPLIANCE WITH ALL LEGAL, REGULATORY, AND SAFETY-RELATED REQUIREMENTS CONCERNING ITS PRODUCTS, AND ANY USE OF CBV COMPONENTS IN ITS APPLICATIONS, NOTWITHSTANDING ANY APPLICATIONS-RELATED INFORMATION OR SUPPORT THAT MAY BE PROVIDED BY CBV.

**Mailing Address:** Component Basics, 1539, 35-Viking Lane, Toronto, M9B 0A2, ON, Canada.

**Email:** [info@componentbasics.com](mailto:info@componentbasics.com)