

Fuses for Semiconductor Protection

CPV10 SERIES FUSES



- Fuses for Semiconductor Protection

IEC60269-6/UL248-19 standard

Size	Rated Voltage	Operating Class	Rated Breaking Capacity
10	1000Vdc	gPV	1000V@20kA

- Product Model

CPV10-XXA B

- Description

- Excellent electric performance, quick protection for PV system, cut down the fault current of the system
- IEC60269-6、UL248-19 /Product design conforms to IEC60269-、 UL248-19
- Product Process Conforms toISO9001
- Product and Package conform to ROHS

● Dimensions

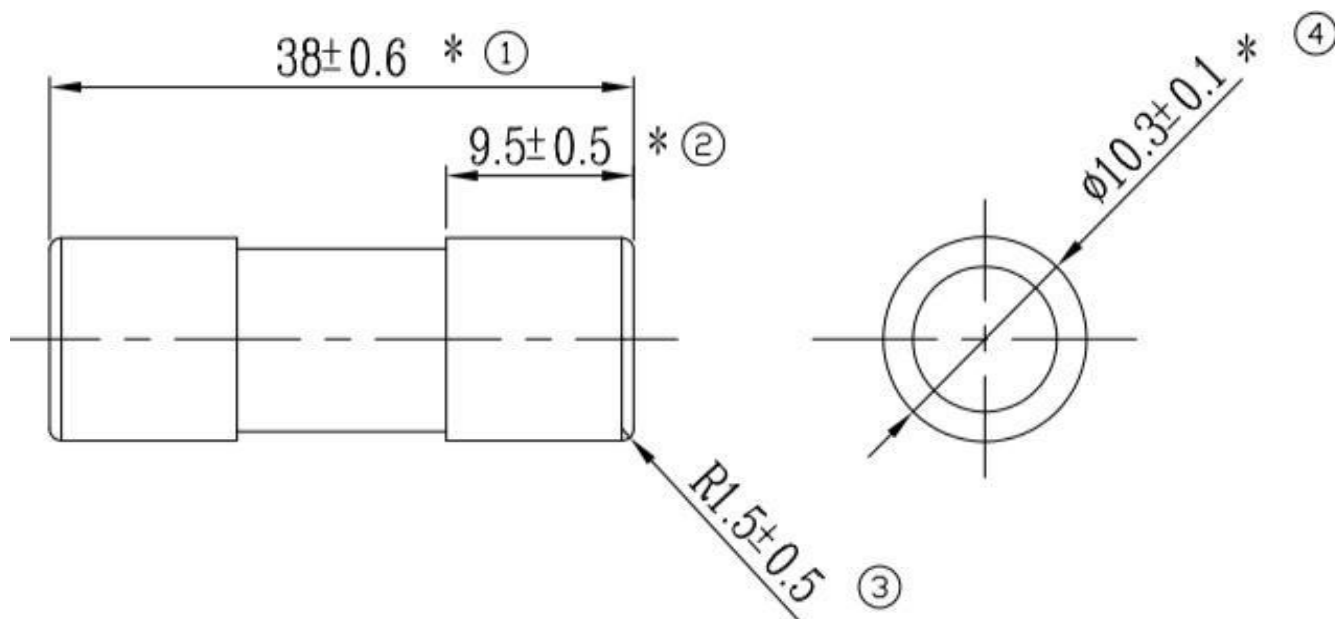

● Selection and ordering data

Rated current 【A】	Rated voltage 【V】	Part Number	Power Loss 【W】	Pre-arcing I2t 【A2S】	Total@1000V I2t 【A2S】	Weight 【Kg/1】	Pack
1	1000	CPV10-1A B	1.4	0.7	1.2	0.01	20
2		CPV10-2A B	1.1	1.2	3.4		
3		CPV10-3A B	1.4	4	11		
4		CPV10-4A B	1.6	9.5	26		
5		CPV10-5A B	1.7	19	50		
6		CPV10-6A B	1.8	30	90		
8		CPV10-8A B	2	3	32		
10		CPV10-10A B	2.2	7	70		
12		CPV10-12A B	2.4	12	120		
15		CPV10-15A B	2.5	22	220		
16		CPV10-16A B	2.6	25	240		
20		CPV10-20A B	2.7	34	350		
25		CPV10-25A B	2.9	120	1250		
30		CPV10-30A B	3.4	165	1820		
32		CPV10-32A B	3.8	230	2700		

- Time- Current Characteristics Curve

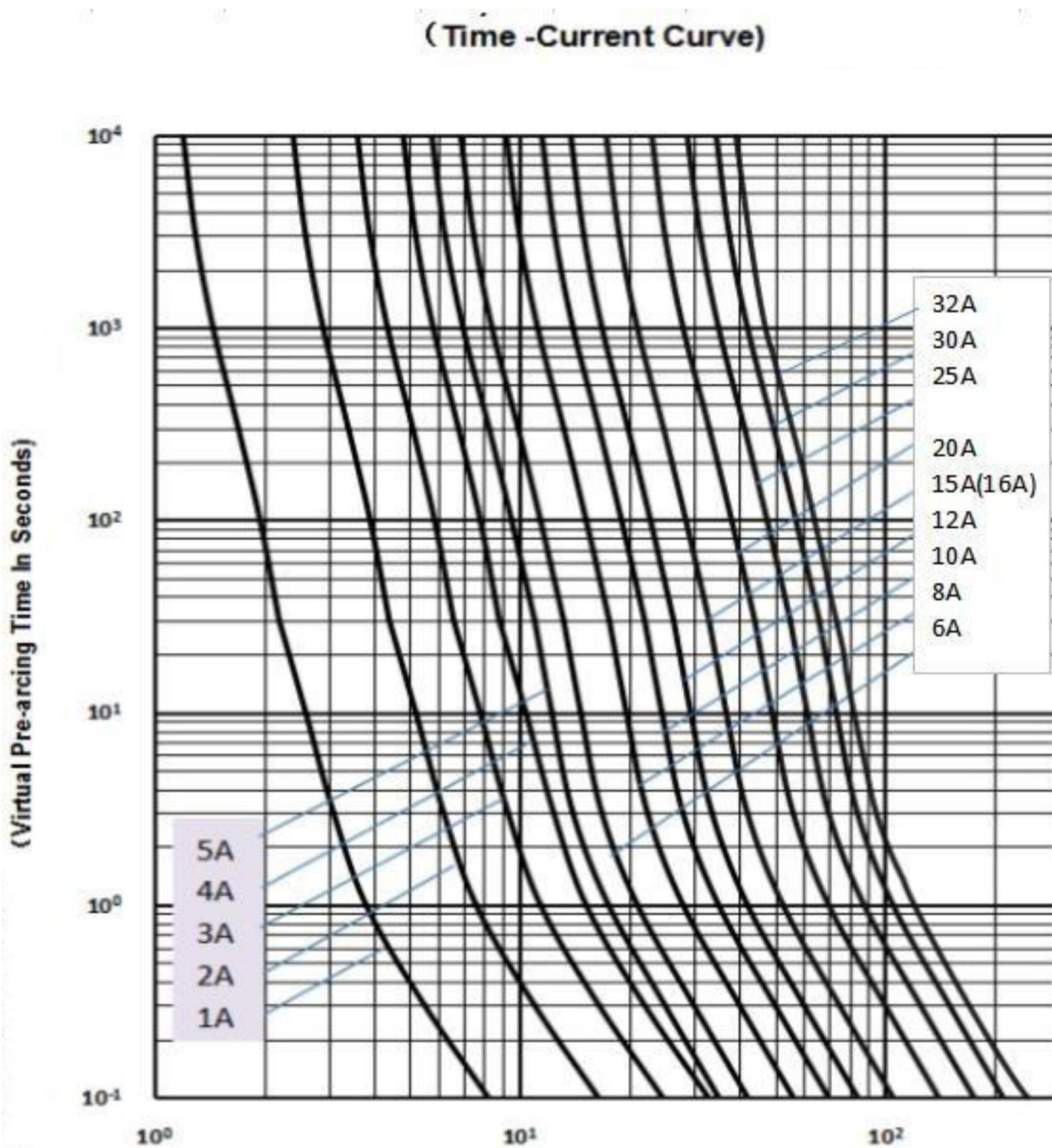

- Selection For The Fuse Amperage

Formula for rated amperage of the fuse

$$I_n \geq \frac{I_{RMS} \times G}{K_t \times K_e \times K_v \times K_f \times K_a \times K_b}$$

- Temperature Correction Factor K_t

Fuses under different ambient temperatures will affect the thermal radiation effect of the fuse's heat. The correction factor K_t values for different ambient temperatures are shown in the following curves:

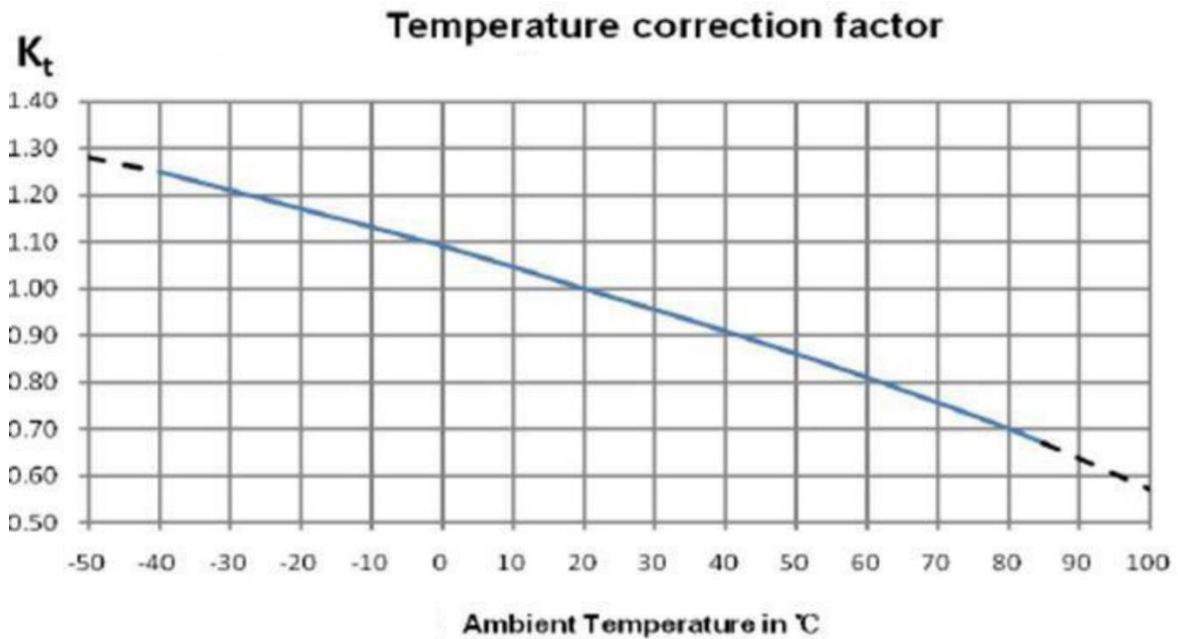

- Thermal Connection Correction Factor K_e

When fuses are installed, the specifications of the copper bars or wires (wire harnesses) directly connected to the fuses will affect the heat conduction effect of the fuses. For different connection copper bars (or wires) selected, the thermal connection correction factor K_e value is shown in the following curve:

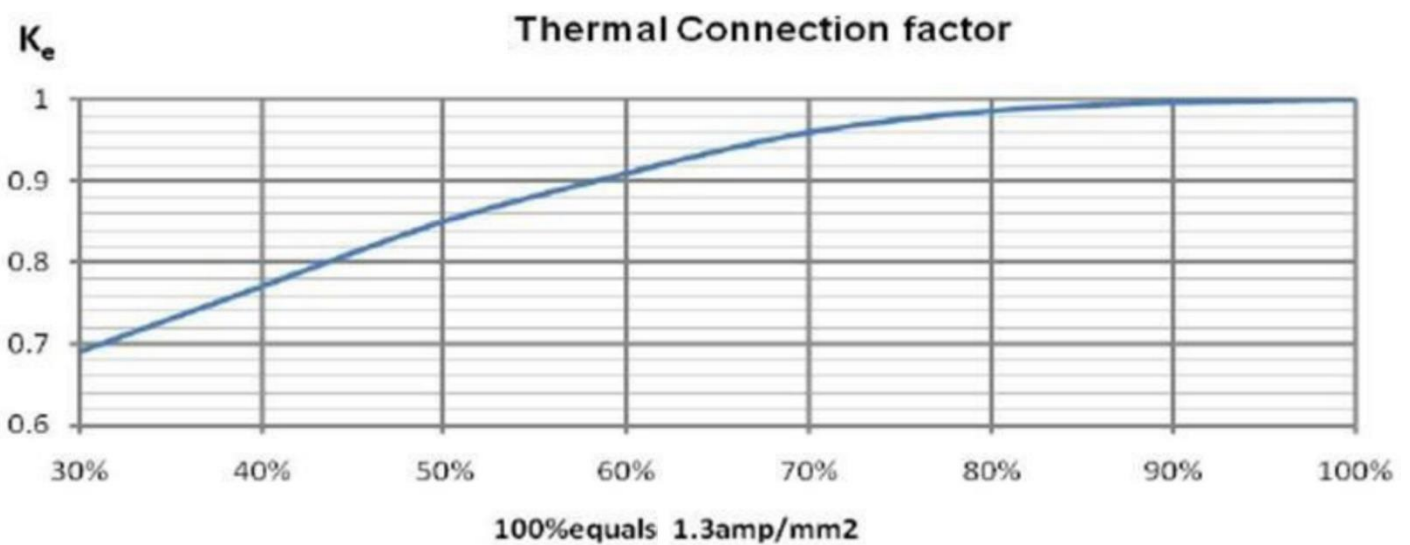

- **Forced Cooling Correction Factor K_v**

For fuses, forcibly increasing air cooling (or liquid cooling) will enhance the thermal convection effect of the fuse's heat, which can increase the fuse's flow rate. The forced cooling correction factor K_v value is shown in the following curve:

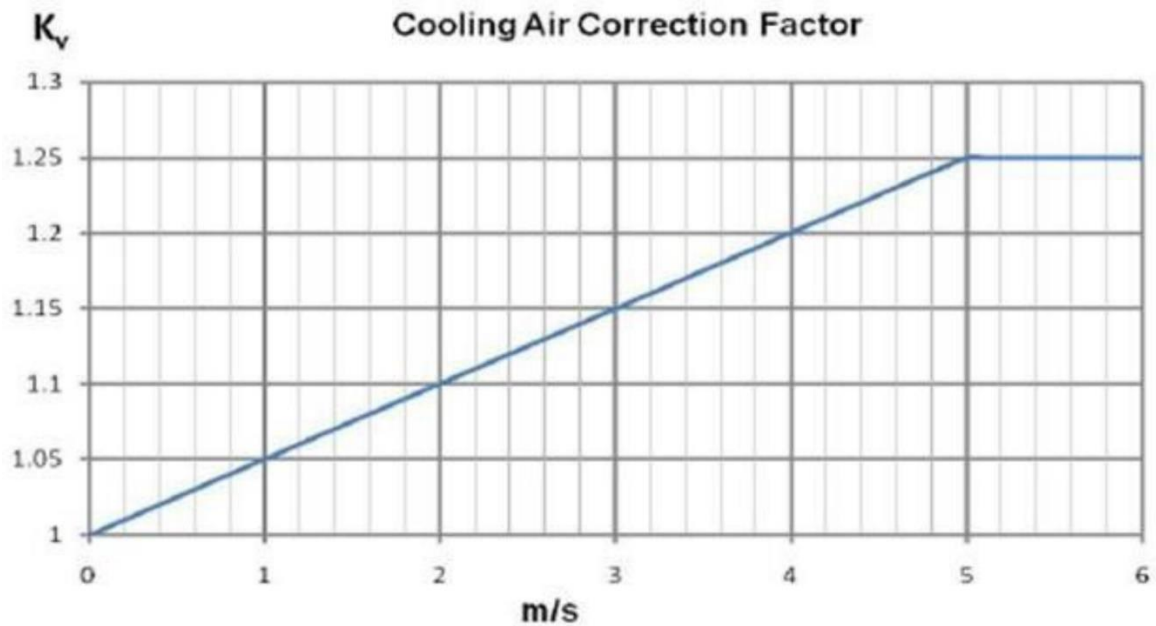

- **Frequency Correction Factor K_f**

When there are high-frequency harmonics in the power grid and the frequency reaches above 1000Hz, due to the influence of high-frequency distortion on the resistance, the capacity of the fuse needs to be reduced. The coefficients are as follows:

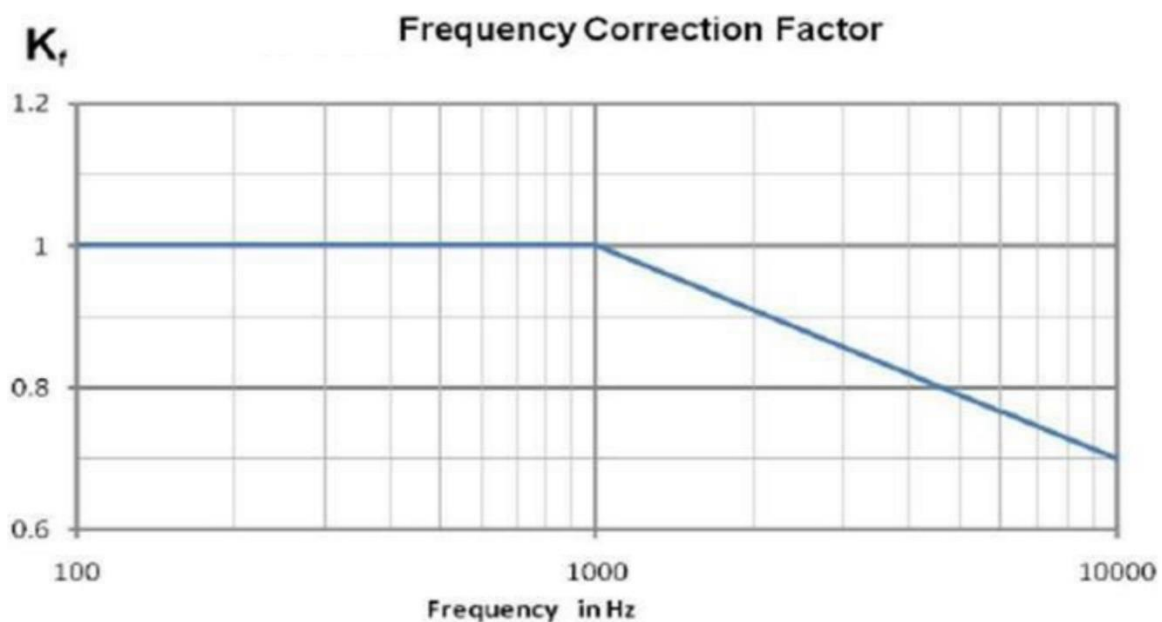

● Altitude Correction Factor K_a

- The normal operating altitude for the fuse is 2000 meters. When the altitude increases, the air becomes thinner, which adversely affects the occurrence of thermal radiation. The impact on heat dissipation can be considered as a derating of 3% to 5% for every 1000 meters of elevation. At the same time, due to geographical conditions, the ambient temperature typically decreases by approximately 6°C for every 1000-meter increase in altitude. To avoid double-counting with the temperature correction factor (K_e), this effect can be considered as offsetting.
- For the fuse used in enclosed environments, if the ambient air temperature inside the sealed enclosure does not significantly decrease with increasing altitude, and can still reach above 40°C , then derating the rated current is required. The rated current should be derated by 3% to 5% for every 1000 meters increase in altitude.
- Regarding the impact of high altitude on insulation strength, since the fuse itself is a conductor during normal operation, only the insulation level of the live parts of the fuse relative to the casing (ground) needs to be considered. Therefore, the impact of high altitude on this aspect can be integrated as part of the overall system's electrical components and does not need to be treated separately for the fuse.

● Installation Environment Correction Factor K_b

Fuses installed in open-type enclosures: $G = 1$

Fuses installed in sealed enclosures: $G = 0.9\text{--}0.95$

Fuses installed in MSD with bolt fastening: $G = 0.8$

Fuses installed in MSD with plug-in connection: $G = 0.7$

● Load Constant G

Different types of load conditions can generate varying levels of inrush current, and the following considerations need to be taken into account:

Principle:

Purely resistive load, no inrush current, $G = 1$.

Resistive load with peak current: $G = 1.1\text{--}1.2$

Highly capacitive load with high peak inrush current: $G = 1.5\text{--}1.7$

● Operating Condition

No	Item	Requirements
1	Operating Voltage	≤1000Vdc
2	Operating Environment	
	Normal Applied Temperatures	-5°C~40°C
	Allowed Operation Temperature	-40°C~125°C
	Relative Humidity	5%~95%
3	Altitude	
	Normal Altitude Location	≤3000m
	Allowed Mounted Altitude	≤5500m
	Atmospheric Pressure	61.6kPa~106.2kPa
4	Storage Environment	
	Normal Storage Condition	-5°C~85°C RH<75%
	Allowed Storage Condition	-40°C~120°C
5	Install Torque	/
6	Pollution level	III
Note:	If exceeding the normal usage conditions, some parameters may need to be corrected within the allowed usage conditions, please contact with Component Basics.	

● ABOUT US

Component Basics ("CBV") datasheets are solely intended to assist designers ("Buyers") who are developing systems that incorporate CBV products (also referred to herein as "components"). Buyer understands and agrees that Buyer remains responsible for using its independent analysis, valuation, and judgment in designing Buyer's systems and products. CBV datasheets have been created using standard laboratory conditions and engineering practices. CBV has not conducted any testing other than that specifically described in the published documentation for a particular datasheet. CBV may make corrections, enhancements, improvements, and other changes to its datasheets or components without notice.

Buyers are authorized to use CBV datasheets with the CBV component(s) identified in each particular datasheet. HOWEVER, NO OTHER LICENSE, EXPRESS OR IMPLIED, BY ESTOPPEL OR OTHERWISE TO ANY OTHER CBV INTELLECTUAL PROPERTY RIGHT, AND NO LICENSE TO ANY THIRD PARTY TECHNOLOGY OR INTELLECTUAL PROPERTY RIGHT, IS GRANTED HEREIN. CBV DATASHEETS ARE PROVIDED "AS IS". CBV MAKES NO WARRANTIES OR REPRESENTATIONS WITH REGARD TO THE DATASHEETS OR USE OF THE DATASHEETS, EXPRESS, IMPLIED, OR STATUTORY, INCLUDING ACCURACY OR COMPLETENESS. CBV DISCLAIMS ANY WARRANTY OF TITLE AND ANY IMPLIED WARRANTIES OF MERCHANTABILITY, FITNESS FOR A PARTICULAR PURPOSE, QUIET ENJOYMENT, QUIET POSSESSION, AND NON-INFRINGEMENT OF ANY THIRD PARTY INTELLECTUAL PROPERTY RIGHTS WITH REGARD TO CBV DATASHEETS OR USE THEREOF.

All products are sold subject to CBV's terms and conditions of sale supplied at www.componentbasics.com. CBV ASSUMES NO LIABILITY FOR APPLICATIONS ASSISTANCE OR THE DESIGN OF BUYERS' PRODUCTS. BUYER ACKNOWLEDGES AND AGREES THAT IT IS SOLELY RESPONSIBLE FOR COMPLIANCE WITH ALL LEGAL, REGULATORY, AND SAFETY-RELATED REQUIREMENTS CONCERNING ITS PRODUCTS, AND ANY USE OF CBV COMPONENTS IN ITS APPLICATIONS, NOTWITHSTANDING ANY APPLICATIONS-RELATED INFORMATION OR SUPPORT THAT MAY BE PROVIDED BY CBV.

Mailing Address: Component Basics, 1539, 35-Viking Lane, Toronto, M9B 0A2, ON, Canada.

Email: info@componentbasics.com